

Schwank – Infrared-Heaters
supraSchwank

THE HEAT IS ON!



supraSchwank

Dimensions and Technical Data

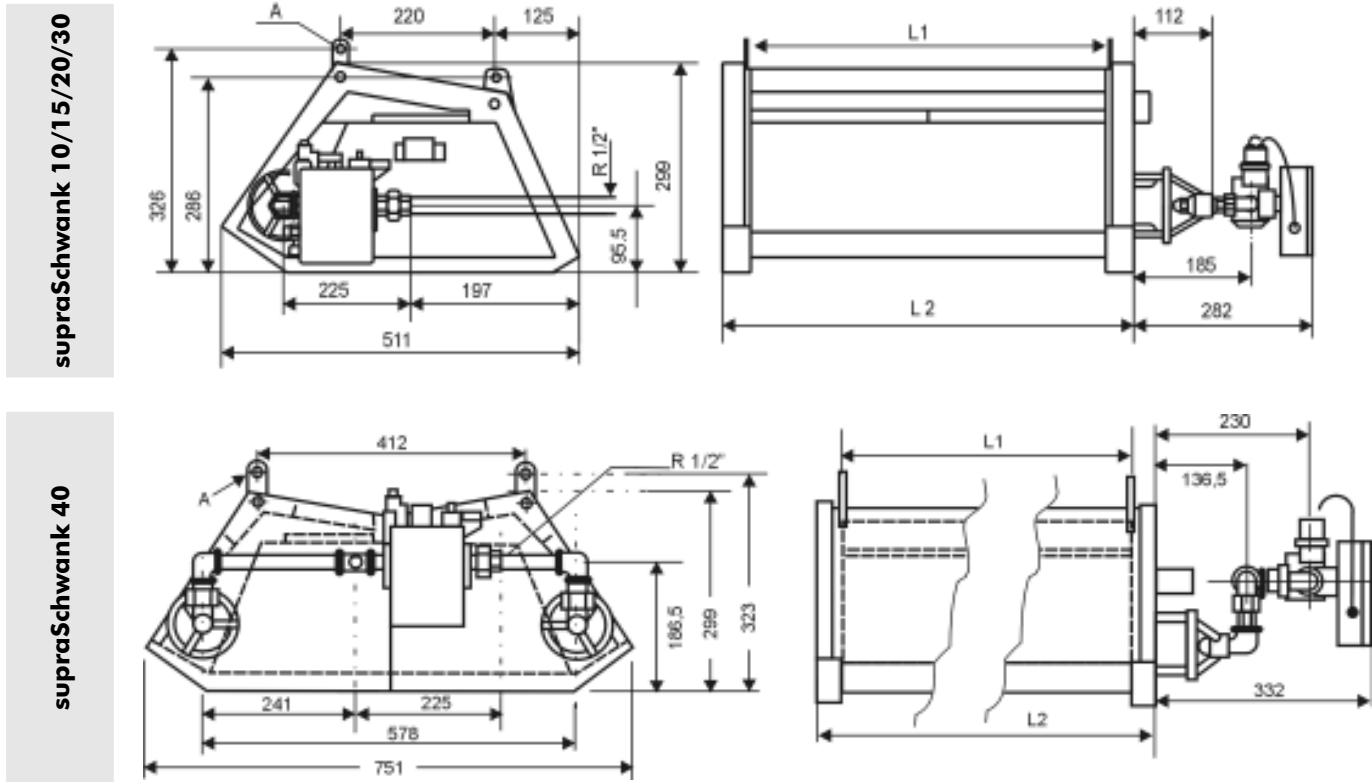

Heater Type	Gas	gas input [kW]	gas consumption 1)	weight appliance [kg]	weight control [kg]	length L2 [mm]	hanging points L1 [mm]
supraSchwank 10 CE-0085AU0376	Nat. gas H	8,5	0,77 m ³ /h	17,0	1,4	629	553
	Propane	8,5	0,60 kg/h	17,0	1,4	629	553
supraSchwank 15 CE-0085AU0376	Nat. gas H	12,7	1,15 m ³ /h	22,4	1,4	906	830
	Propane	12,7	0,90 kg/h	22,4	1,4	906	830
supraSchwank 20 CE-0085AU0376	Nat. gas H	17,0	1,54 m ³ /h	29,0	1,4	1184	1108
	Propane	17,0	1,20 kg/h	29,0	1,4	1184	1108
supraSchwank 30 CE-0085AU0376	Nat. gas H	25,4	2,32 m ³ /h	38,0	1,4	1738	1662
	Propane	25,4	1,80 kg/h	38,0	1,4	1738	1662
supraSchwank 40 CE-0085AU0376	Nat. gas H	34,0	3,08 m ³ /h	46,0	2,3	1181	1108
	Propane	34,0	2,40 kg/h	46,0	2,3	1181	1108

1) gas consumption: Nat. gas H: H_{g,n} = 11,08 kWh/m³ Propane: H_{g,n} = 14,3 kWh/kg

Application

appliance for industrial heating,
transfer of radiant heat is through infrared radiation

Min. connection pressure

single-stage control:	double-stage control:
Nat. gas H: 16 mbar	Nat. gas H: 24 mbar
Propane: 32 mbar	Propane: 65 mbar
	supraSchwank 15:
	Nat. gas H: 30 mbar

Max. Connection Pressure

Nat. gas, Propane: 100 mbar

Electrical Connection

Single-phased AC 230 V, N, PE
50 Hz (ca. 33 VA)

Exhaust Flue

according to national standards

Gas Connection

threaded fitting R=1/2", female

Hanging Points

See 4 hanging points (A) at the drawing