



**EVERYTHING YOU  
WANTED TO KNOW ABOUT  
AC/DC MOTORS  
(BUT WERE TOO EMBARRASSED TO ASK!)**



**TRUST**  
*Quartz*  
**TO HELP SAVE  
THE WORLD**

## What are DC motors and how do they differ from AC?

In all electrical motors, be they DC (direct current) or AC (alternating current), the motive power is generated by the attraction and repulsion of magnetic fields in sequence. One of these magnetic fields is present in the motor part that does not move (the stator) and the other is in the rotating part (the rotor). The magnetic field in the stator can be produced by a permanent magnet (as in the case of a simple DC motor) or by a coil with a current passing through it. The magnetic field in the rotor is generated by an electrical current passing through a conducting coil.



## DC Motors

In a simple DC motor, the magnetic fields are produced by a permanent magnet in the stator and by field coils in the rotor. The stator field does not change its polarity and the current, being direct current, is always flowing in one direction. A mechanism is therefore required to change the magnetic field polarity in the correct sequence in order to get the attraction/repulsion sequence that produces the motive power. This component is called the Commutator and its operation is best described by examination of the diagram below (fig 1).

As can be seen from the diagram, the direct current is supplied to the rotor field coils by a set of brushes that make mechanical contact with a set of electrical contacts on the rotor (this arrangement is the commutator), thus forming an electrical circuit between the DC electrical source and the armature coil-windings.

As the armature (the bit with the coils on it!) rotates on its axis, the stationary brushes come into contact with different sections of the rotating commutator thus making and breaking the electrical circuit and hence generating changing magnetic fields. The commutator and brush-system form a set of electrical switches, each firing in sequence, such that electrical-power always flows through the armature-coil closest to the stator. In the pictures that follow, the principle is clearly explained. In the left hand picture

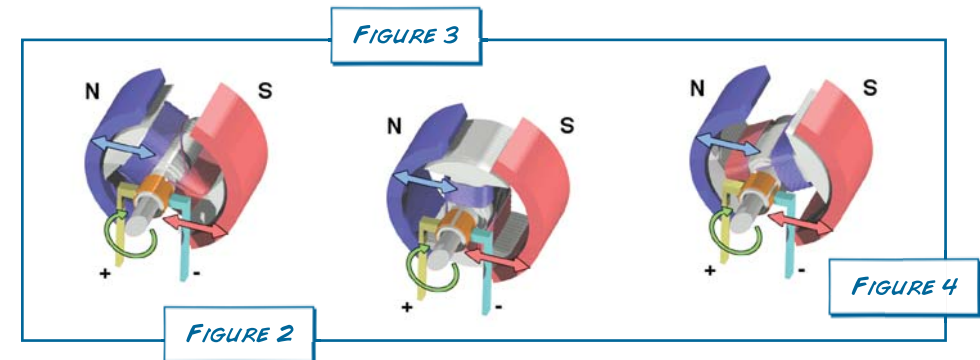
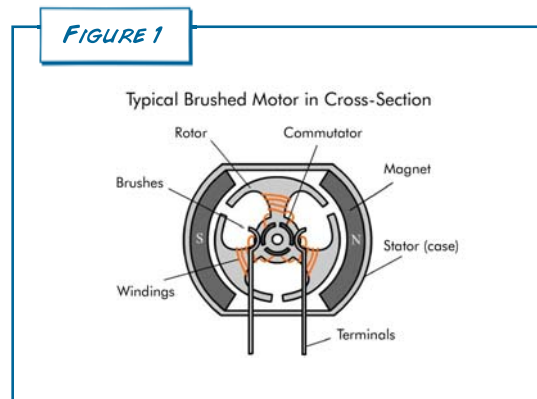

(fig 2) the left side of the rotor is pushed away from the left stator and the rotor starts to rotate. In the centre picture (fig 3) the rotor is vertical and its inertia maintains the rotation. In the right hand picture fig 4) the rotor has passed the vertical and the commutator has reversed the direction of the current thus causing the forces to reverse and maintaining the rotation.

A variation on the above design is to use an intelligent electronic controller to perform the switching that the commutator performs. By doing this, the brushes are no longer required and these motors are known as brushless DC motors (Didn't need Brain of Britain to get that one - eh!). They also are known as electronically commutated (EC) DC motors, for obvious reasons. In order to generate the magnetic field in the correct sequence, the controller must know the position of the rotor at all times.

Some designs use Hall Effect semi-conductor devices whilst others measure the back emf in the unconnected coils to determine the position. Because this latter design does not have a specific sensor fitted they are known as sensorless controllers (naming these devices is obviously the hard bit!). Because there is no mechanical switching, the permanent magnets can be in either the stator or the rotor and vice versa for the field coils. It is in fact common to have the permanent magnets made into a rotor with the field coils in the stator as illustrated in the picture below (fig 5).

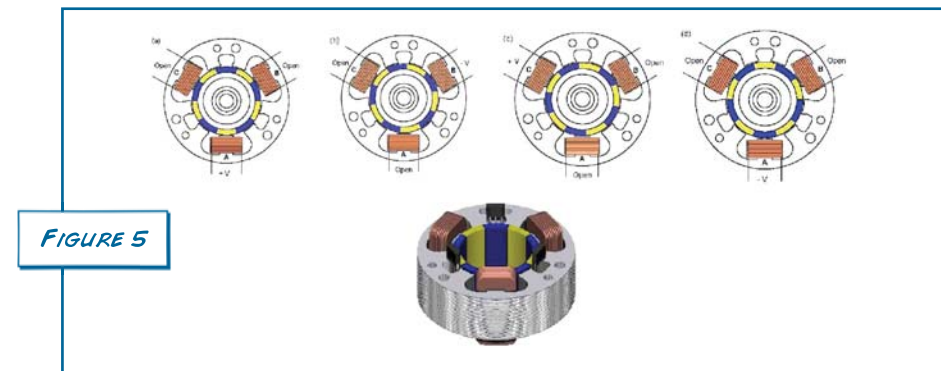

## AC Motors

Whilst relying on the interaction of magnetic fields, AC motors operate in a different manner. Because the current is changing 50 times per second (50Hz), passing this current through a conducting coil automatically generates a changing magnetic field. If a conductor that is free to rotate is placed in such a field, an emf (electromotive force) is generated within it that has the effect of modifying the magnetic field, weakening it on one side and strengthening it on the other. If the main magnetic field can be made to rotate then the conductor will be dragged along by it and will also rotate. The motor still has a stator (coils that generate the rotating magnetic field) and a rotor (conductor that is dragged along and rotates).

The conductors are placed longitudinally in the centre of the motor with their ends connected together. Such an arrangement looks like the cage that is provided for rodent pets to play and exercise in and is hence called a Squirrel Cage (you were probably guessing Guinea Pig Cage!). Such a motor is therefore called a Squirrel Cage motor.

Generation of the rotating magnetic field is easy if three phase electricity is available as the phases lead/lag each other by  $120^\circ$ . By applying each phase to a field coil in turn, a rotating magnetic field is immediately produced. With single phase electricity it requires a little more thought but the application of a capacitor to the circuit enables a lagging current to be produced with the attendant rotating magnetic field. A cut-away drawing of a typical AC motor is shown in fig 6 below.

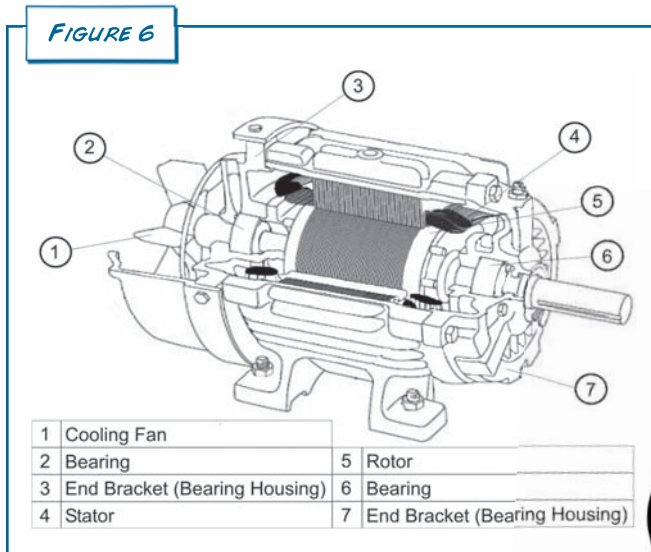

## Motor Efficiency AC Vs DC

The efficiency of any electrical motor is defined in a similar manner to most things in life as being the ratio of the output to the input. As we do not live in an ideal world, there will always be losses connected to anything we do. In the case of the motors these losses will either be mechanical (friction in bearings or in the commutator) or electrical (slippage in the magnetic field, losses in the transformation or rectification of current etc).

Mechanical losses are common to both motor types if brushless DC motors are compared to their AC counterparts, however, the electrical losses differ for AC and DC. In an AC motor the electrical losses are made up of heating effect in stator and rotor ( $I^2R$ ), Iron loss in the stator and rotor cores and windage loss. These losses are not constant and are influenced by many parameters including the air gap between rotor and stator, the amount that the rotor lags the rotating magnetic field (the slip), the applied load and the voltage applied to the motor.

The latter effect is very important as speed control of induction type AC motors is difficult and is usually achieved by reducing the applied voltage. An example of how the voltage reduction affects efficiency (Power factor) is shown in the table below.

Voltage	Applied Power W	Effective Power W	Reactive Power VA	Power Factor
190	154.1	146	49.30	0.95
170	128.8	118	51.63	0.92

Large AC motors at design voltage and loadings can have efficiencies in the region of 95%. However, the smaller motors that are used in fan coils have much lower efficiencies due to the fact that the copper turns at the end of the stator that do no work, make up a substantially greater part of the winding than their larger brothers. Their efficiency can be as low as 40%.

Another way of describing the efficiency for applications where the motor drives a fan is to provide figures for the "Specific Fan power." This coefficient states the amount of energy in Watts required to move a given volume of air (litres) in a given time (seconds). Whilst it is concerned with more than the electrical losses and has effects of fan design and unit application involved in it, providing that these factors remain constant it is a practical means of providing motor comparison. The table on page 5 demonstrates the variation of specific fan power for a standard AC motor fitted to a fan coil.

Static (Pa)	Specific Fan Power					
	Speed 1	Speed 2	Speed 3	Speed 4	Speed 5	Speed 6
10	0.40	0.53	0.61	0.69	0.70	0.73
20	0.52	0.60	0.64	0.72	0.74	0.76
30	0.60	0.67	0.73	0.79	0.80	0.83
40	0.66	0.70	0.75	0.80	0.81	0.84
50	0.72	0.73	0.77	0.80	0.81	0.84
60	0.78	0.79	0.80	0.84	0.86	0.87
70	0.84	0.85	0.86	0.88	0.89	0.90

DC motors, because of the fact that they do not require to induce currents to generate opposing magnetic fields etc, are more efficient and use less input energy for a given power output. If one were to look only at the conversion of the DC supply to the motor into motive power in splendid isolation, efficiencies (power factors) in the region of 80% (0.8) are achieved. They can also be easily speed controlled with infinitely variable control from 0 to 100% being achieved with little or no effect on the motor efficiency.

Unfortunately, as is always the case in life, that is not the whole story. There are losses in the conversion of AC to DC and, because a DC motor is a non-linear load, harmonics are generated that result in a poor power factor. If one takes into account these effects in calculation of efficiency (output/input), figures for power factor as low as 0.5 are produced.

## Harmonics and All That Jazz

As stated above, a DC motor is a non-linear load which generates harmonics. For the electrically astute amongst you, harmonics are defined as "Multiple integers of a fundamental frequency created by non-linear loads." So there you have it! What this practically means is that they are non productive losses in the system that can be manifested in many ways, some of which are listed below.

- Increased heating effect on electrical distribution equipment and cables
- Increased electrical insulation stresses
- Electronic mistimings; Variable speed drives, computers etc
- Capacitor overloads – premature failure
- Flickering fluorescents
- Safety device trips and fuse operations

Legislation demands that harmonics must be kept below certain levels on the main supply and, to achieve this by preventing their escape from the rectification/commutation/motor package, a filter is sometimes used. Interestingly, if the filter choice is judicious, not only does it prevent the escape of the harmonics onto the supply network but a reduction in the harmonics is achieved with an improvement in the efficiency. With a well-matched filter the power factor can rise to 0.65. If the application of such a simple filter results in power factor improvement, the process is known as "Passive Power factor Correction." A sample filter device is shown below.

Electronics that can measure what is occurring in the process and take corrective action are available. This process is known as "active Power factor Correction" and application of such a device will achieve power factors of 0.93. The device can be built into the electronics that comprise the electronic commutator making a neat package. This, coupled with the fact that DC motors use less energy to start with, results in a highly energy efficient solution.

## Part L, Energy Efficiency and Motors

In 2006, the UK building regulations were changed in an attempt to make buildings, both new and refurbished, more energy efficient in order to reduce the Carbon Dioxide emissions related to them thus combating the global warming trend. One of the areas specifically highlighted in the sections relating to energy consumption (Parts L1 & L2) was that of air movement.

A limit for the specific fan power of various types of equipment was set with the intention that the average specific fan power of the total fans of each type used in the building should be below the limit if planning approval is to be granted. A table giving all of the various specific fan powers is not in the Part L document but is in

FIGURE 7



an accompanying HVAC document that is referred to in the Part L document (you think you're confused?).

For fan coils, the product to which this booklet is specifically aimed, the limit for total average specific fan power is 0.8 w/l/s when operating at 25% of design airflow volume.

## So, Are You AC or DC?

Taking account of the technical blurb provided so far it is obvious that the AC/DC decision is not as simple as first thought. With alternatives possible, the decision making process should follow the same lines as with any other product or service, namely, choose the product that most closely meets the specified requirement at the minimum cost and with the desired quality level.

When the Part L proposals were first discussed, the immediate reaction was that this requirement could only be satisfied by the use of a DC motor. However, lets examine the

Static (Pa)	Specific Fan Power					
	Speed 1	Speed 2	Speed 3	Speed 4	Speed 5	Speed 6
10	0.40	0.53	0.61	0.69	0.70	0.73
20	0.52	0.60	0.64	0.72	0.74	0.76
<b>30</b>	<b>0.60</b>	<b>0.67</b>	<b>0.73</b>	<b>0.79</b>	<b>0.80</b>	<b>0.83</b>
40	0.66	0.70	0.75	0.80	0.81	0.84
50	0.72	0.73	0.77	0.80	0.81	0.84
60	0.78	0.79	0.80	0.84	0.86	0.87
70	0.84	0.85	0.86	0.88	0.89	0.90

specific fan power table for a unit fitted with an ac motor, that we showed previously. Note that we have now highlighted those conditions where the fan coil exceeds the limit and have also identified the specific fan powers at 30Pa static (the nominal design condition).

Immediately it can be seen that a reduction in speed and hence air flow volume reduces the specific fan power. Furthermore, at most speeds where such products operate, the unit is operating below the limit of 0.8W/l/s and is therefore complying with Part L. This can also be demonstrated graphically as shown on graph 1 on page 8.

Note that on the graph, 27 fan speeds are shown. These relate to the 27 possible speeds available using the multi-tapped transformer. If full design airflow is at the highest speed it is easy to see that the AC motor will comply with Part L for 75% of its operating envelope.

A similar graph for the corresponding EC\DC motor is shown in graph 2 on page 8. The graph demonstrates the overall improvement in efficiency that a DC motor provides and shows compliance with Part L across the complete range of operation.

If compliance with the requirement in Part L is the only criteria it can be seen that for most applications AC or DC motors can be used. In this case, the AC motor would be substantially cheaper and is therefore likely to remain the choice for designers. It is when other factors are taken into account or other features are required that the DC motor becomes the most likely choice. Several such likely scenarios are described below.

If there is a burning desire to utilise the most energy efficient products for moral or corporate reasons regardless of capital cost, then the DC motor has to be the choice. There is however a financial benefit when one considers the running cost and longevity of the DC motor and, depending upon the figure used for energy cost, a payback within 2½ years can be demonstrated. As the life of the product is likely to be in the order of fifteen years, it does

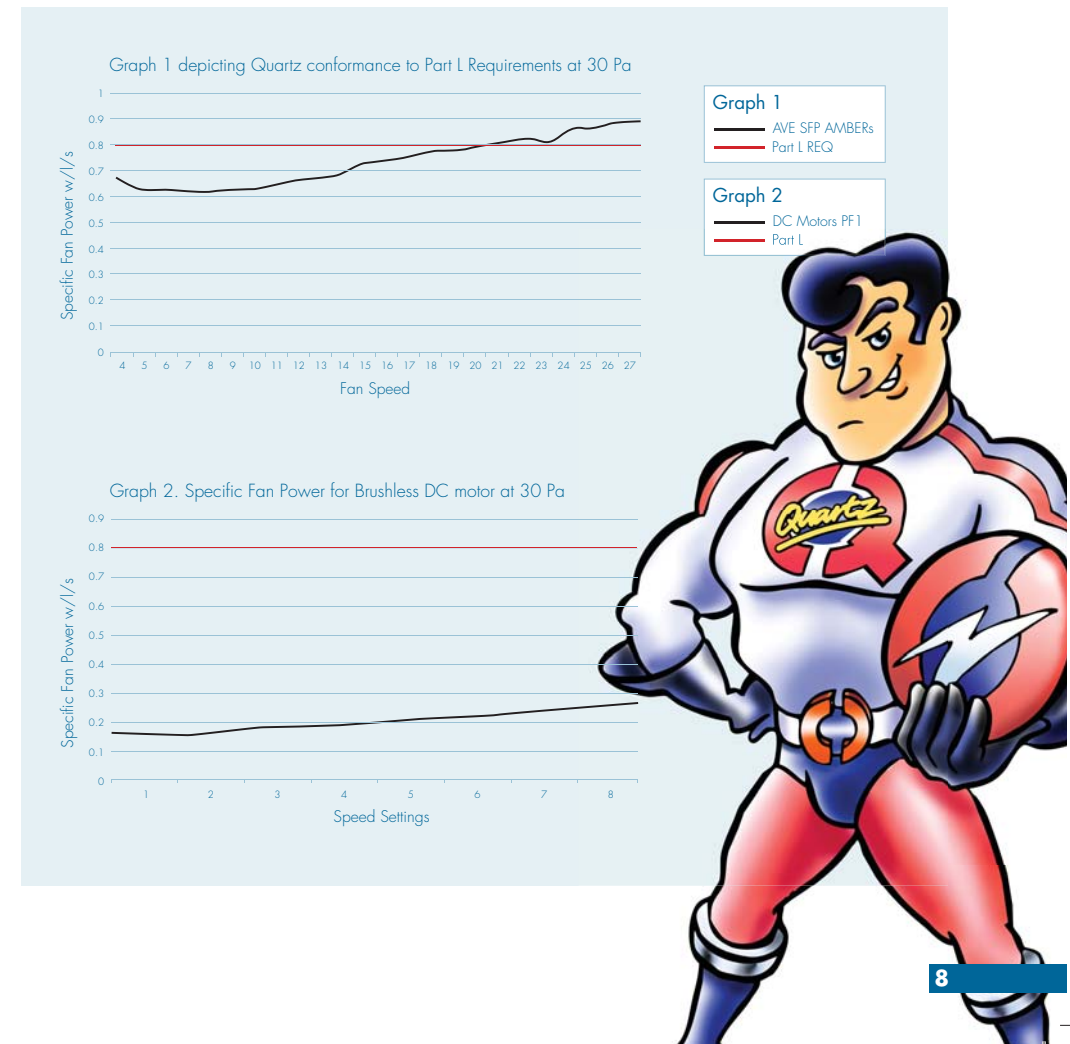

Motor type	Voltage	Airflow l/s	Input Power W	Specific Fan Power w/l/s	Consumption 12 hr day Kwh	% Improvement
AC	230	157	118	0.75	1.42	
DC	230	163	50.4	0.31	0.61	57%

not require a financial genius to ascertain that the most cost effective option when whole life costing is used is the EC\DC motor. An example of the % improvement is shown in the table above.

As previously explained, DC motors have the ability for infinitely variable speed control. This feature can be coupled with intelligent controllers to provide the following positive benefits.

- a) Self calibration of airflow volume eliminating the requirement for airside commissioning.
- b) Modification of fan speed in relation to room load thus reducing running costs.
- c) Potential for application in a multi zone fan coil unit that can serve several areas independently thus reducing capital costs.

So, now being in possession of the facts, you can intelligently make the decision AC or DC.

## Self Calibration – Too Good To Be True?

One of the possible features mentioned above is that of a self calibrating fan coil. The description of such a device would be a unit that, when correctly installed with supply ductwork that has similar static pressure losses on each leg could, by pressing a button on the controller, be able to effectively measure the pressure, compare this with the known fan curve and the airflow volume required by design and then adjust its speed to achieve the correct airflow volume.

If this state is reached, there would be either a reduced or no requirement for airside commissioning. Sound's too good to be true? Well you would be wrong. Such a product exists today and is available either as a stand alone addition to a fan coil with a DC motor or as part of a greater package, Quartz Solutions. This is only one of the numerous possibilities that DC motors bring to what is viewed as essentially a staid, boring and technically basic product.

## To Summarise

This booklet attempts to clarify the situation regarding AC Vs DC fans and to dispel some of the myths that have been circulating within the industry as a result of the perceived opportunity for volume sales and market positioning. Starting with the basic features, the following is a list of the salient features for each motor.

AC Motors – Low capital cost (relatively), high efficiency at full load, reducing efficiency at part loads, speed control by variation of voltage requiring multi tapped transformer, multi tapped windings or resistors, high reliability.

DC Motors – Higher capital cost than AC, require less energy than AC equivalent, efficiency high at all operating points, infinitely variable speed, longer life than AC, in most instances require filter to prevent escape of harmonics, improved by power factor correction (active and passive) although this adds cost.

Finally, don't get confused by the stories of efficiency when considering DC fans as it is not possible to break the laws of Physics. There has been a somewhat irresponsible practice of using only the energy that is directly attributable to motive power as the input in the calculation of efficiency. This has been done in an attempt to disguise power factor figures that, on first examination, appear poor. DC motors are highly energy efficient in the first place and have nothing to hide. If one has figures for the output and the total input to the system the efficiency is simply the output divided by the input. For the DC motor it is the input to the rectifier/controller that must be measured not just the input to the motor.



## Useful Info

Specific Fan Power = Power input/Air Flow Volume/Time = W/l/s

Part L limit for Specific Fan Power, Fan Coils = 0.8 W/l/s

### Typical Fan Coil Motor Efficiencies (Power factor)

ac motor	0.45
Basic EC\DC motor	0.5
Passive power factor correction EC\DC motor	0.63
Active power factor correction EC\DC motor	0.93



Quartz Division, TEV Limited,  
Armytage Road, Brighouse, West Yorkshire, UK HD6 1QF  
sales@quartz.co.uk www.quartz.co.uk