

High efficiency wall hung condensing boiler with ultra low NOx emission

Outputs:	Q30	5.6 - 28 kW
	Q45	7 - 40 kW
	Q65	11 - 61 kW
	Q85	14.4 - 84.2 kW
	Q115	18 - 115 kW

SEDBUK 'A'

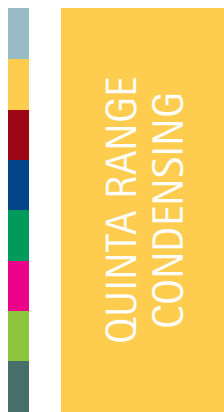

# Quinta Range

Condensing Boilers



# Introduction

Remeha Quinta Range are compact wall hung condensing boilers. Lighter and more efficient, their small dimensions make them ideally suited for modular arrangements.

An optional optimising/ weather compensating control system is available to ensure maximum efficiency.

The boilers can be installed on both new and retrofit installations.



## Contents

	page
Introduction	2
Boiler description	2
Typical boiler construction	3
Efficiency Information	3
Advantages at a glance	4
Operating principle	4
Dimensions	4
Technical data	5
Typical Installation	6
Typical flue systems	7-8
Electrical installations and controls	9-11

## Boiler description

The Remeha Quinta Range are wall hung, condensing boilers which may also be installed free standing on a suitable frame (option). The one piece, cast aluminium heat exchanger and other major components are contained within a sealed air box. This forms the main boiler casing with a removable front section for maintenance purposes. All electrical and electronic controls are contained within the instrument panel mounted behind the drop-down lower front panel.

The combined flue gas outlet and combustion air inlet are mounted on the top of the boiler, with the flow, return, gas and condensate connections located at the bottom.

The boiler is suitable for room-sealed or open flue applications. It has been designed for central heating and indirect hot water production. It must be installed on a fully pumped system and is suitable for use on both sealed and open vented installations (minimum operating pressure of 0.3 bar open vented and 0.8 bar pressurised).

The pre-mix, down-firing gas burner (NG or LPG) with its gas/air ratio control system, ensures clean, trouble free operation with higher than average efficiencies (of 110% (NCV)) in the condensing mode, combined with ultra low NO<sub>x</sub> and minimum CO emissions. The standard control package allows actual and set values to be read and adjusted on the built-in digital display which also provides normal operating and fault code indication. An intelligent, advanced boiler control (abc) continuously monitors the boiler conditions, varying the heat output to suit the system load. The control is able to react to external "negative" influences in the rest of the system (flow rates and air/gas supply problems) maintaining boiler output for as long as possible without resorting to a lock out condition. At worst the boiler will reduce its output and/or shut down (shut-off mode); awaiting the "negative" conditions to return to normal before re-starting.

The 'abc' control cannot override the standard flame safety controls.

The boiler meets the requirements of the EC regulations and directives:

- 90/396/EEC Gas appliances directive
- 92/42/EEC Efficiency directive
- 73/23/EEC Electrical low voltage directive
- 89/336/EEC E.M.C. directive

CE Certification

Remeha Quinta 30 - PIN: 0063BM3043

45/65/85/115 - PIN: 0063BL3253

## Typical boiler construction

1. Automatic air vent
2. Air supply fan
3. Gas combi-block (with governor)
4. Gas injector/venturi (not shown)
5. Cast aluminium heat exchanger
6. Temperature sensor - return
7. Air inlet tube
8. Pressure gauge (not shown)
9. Control panel
10. Facility for incorporating a rematic® weather compensated boiler control
11. Heat exchanger inspection cover
12. Sight glass
13. Combined ignition/ionisation probe
14. Temperature sensor - flow (not shown)
15. Pre-mix burner

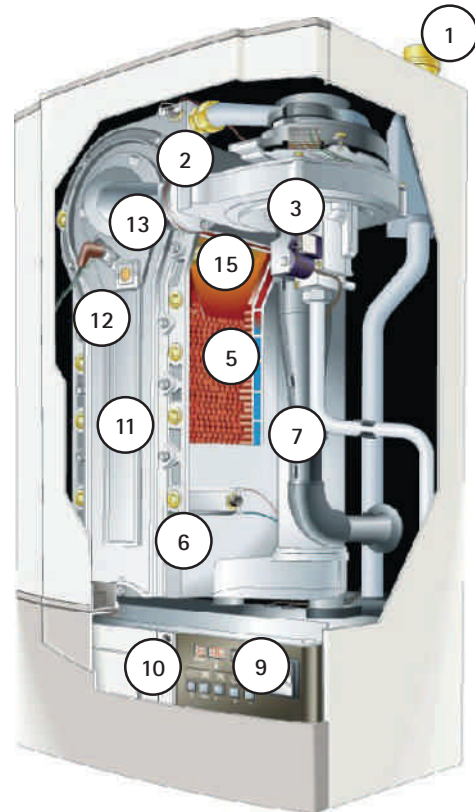

Quinta 45/65 illustrated

## Efficiency information

### Annual efficiency

Up to 109% at Hi (98% at Hs) at an input of 30% and a return temperature of 30°C.

### Heat to water efficiency

- a. Up to 99% at Hi (89% at Hs) at an average water temperature of 70°C (80/60°C) - Quinta 30, 45 & 65.
- b. Up to 98% at Hi at an average water temperature of 70°C (80/60°C) - Quinta 85 & 115.
- c. Up to 110% at Hi (99% at Hs) at an average water temperature of 35°C (40/30°C) - Quinta 30, 45 & 65.
- d. Up to 106% at Hi at an average water temperature of 35°C (40/30°C) - Quinta 85 & 115.

Note: NCV = Hi, GCV = Hs

## Application information

The Quinta Range can be used on all new and refurbishment projects in both single and multiple configurations. Conventional and room-sealed flue system capability means that the boiler can be sited almost anywhere within a building. The Remeha weather compensators (options) are able to communicate directly with the boiler controls (two wire) to make full use of its fully modulating feature, ensuring that the boiler closely matches the system demand at all times. External control systems (BMS) can be interfaced with the boiler to provide on/off, high/low or modulating (0-10v) control options.

*The wall hung  
Quinta from Broag.  
More power in a  
smaller space.*

# Advantages at a glance

- High efficiency: 110% NCV at 40/30°C (99% GCV)
- Boiler control:
  - a) Modulating (18-100%)
  - b) High/low (18-100%)
  - c) On/off
- Premix burner for clean combustion
- Low NO<sub>x</sub> < 25ppm (O<sub>2</sub>=0%, dry)
- Quiet operation <48 dBA
- Digital display
- Data file for storing information
- Remote signalling options
- Cast aluminium heat exchanger
- Easy maintenance
- Built-in calorifier control
- Options for modular control and/or weather compensator
- Control 0-10V signal or volt free
- PC connection
- Advanced boiler control, Remeha's 'abc', for reliable heat delivery
- Conventional or "room-sealed" operation
- Cascade packages for up to 6 boilers
- Quick and easy installation
- Space saving
- For use with natural gas and L.P.G. (Some models require a conversion kit)









## Operating principle

Combustion air is drawn into the closed air box, by a variable speed fan, through the air inlet connection from the plant room (open flued) or from outside via the concentric flue system (room-sealed). On the inlet side of the fan is a specially designed venturi which is connected to the outlet side of the gas combi block.

Depending on the demand (under the dictates of flow/return sensor and other external/internal control inputs) the electronic control unit directly monitors the volume of gas and air being delivered to the premix burner. This mixture is initially ignited by the combined ignition/ionisation probe which then monitors the state of the flame. Should the flame not ignite or be unstable, within the pre-set safety time cycle, the controls will shut the boiler down (after 5 attempts) requiring manual intervention to reset the boiler. The digital display will also indicate a flashing fault code confirming the reason for the failure.

## Dimensions

### Quinta 30

-  Return connection ø 22 mm o/d
-  Second flow connection ø 22 mm o/d (optional for DHW production with 3-way valve)
-  Flow connection ø 22 mm o/d
-  Gas connection ø 15 mm o/d
-  Condensate connection 25 mm o/d (plastic)
-  Combustion air supply connection ø 125 mm i/d
-  Flue gas connection ø 80 mm i/d
-  Holes for mounting bracket
-  Air vent discharge

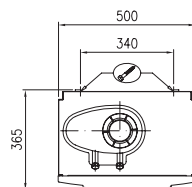



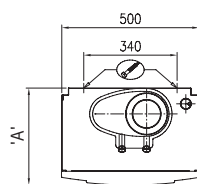
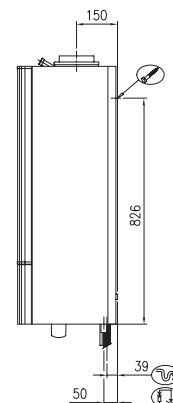
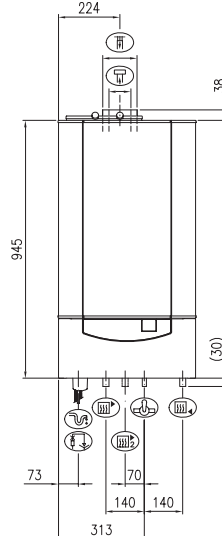

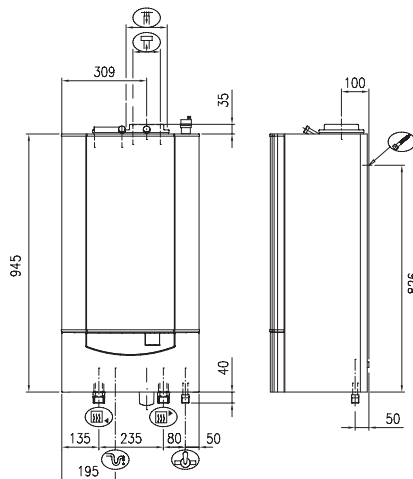

Concentric Pipe Flue



Dimension 'A'  
Quinta 45 65 = 360  
Quinta 85/115 = 452



### Quinta 45/65/85/115

-  Flow connection 1/4" BSP (m) Et 1" BSP (f)
-  Return connection 1/4" BSP (m) Et 1" BSP (f)
-  Gas connection 3/8" BSP (m)
-  Condensate connection 25 mm o/d (plastic)
-  Flue gas connection 80 mm i/d (Quinta 45) and 100 i/d (Quinta 65/85/115)
-  Combustion air supply connection 125mm (Quinta 45) and 150 i/d (Quinta 65/85/115)
-  Holes for mounting bracket

## Technical data

Boiler type		Quinta 30	Quinta 45	Quinta 65	Quinta 85	Quinta 115
<b>General</b>						
Casing colour	BS RAL	9016				
Boiler control options (External input)		On/off, High/low, Analog 0-10V				
(Two wire control)		Communicating Modulation				
Nominal output (80/60°C)	kW	5.6 - 28.0	8.0 - 40.0	12.0 - 61.0	14.1 - 84.2	16.6 - 107
Nominal output (40/30°C)	kW	5.9 - 29.6	8.9 - 43.0	13.3 - 65.0	15.8 - 89.5	18.4 - 114
Nominal input (GCV / Hs)	kW	6.3 - 31.6	9.1 - 45.7	13.6 - 68.8	16.2 - 95.3	19.1 - 123.2
Nominal input (NCV / Hi)	kW	5.7 - 28.5	8.2 - 41.2	12.2 - 62.0	14.7 - 86.0	17.2 - 111
Weight dry	kg	43	57	64	72	74
Noise level at 1M from boiler	dBA	<44		<48		<52.5
<b>Gas and flue details</b>						
Min/max Inlet pressure natural gas	mbar	15 - 50	17 - 30	17 - 30	17 - 30	17 - 30
Min/max Inlet pressure propane	mbar	37 - 50	37 - 50	37 - 50	37 - 50	37 - 50
Gas consumption (natural gas)	m <sup>3</sup> /h	0.6 - 3.2	1.0 - 5.0	1.5 - 7.5	1.5 - 9.1	1.8 - 11.7
Gas consumption (propane)	m <sup>3</sup> /h	0.3 - 1.2	0.3 - 1.7	0.5 - 2.5	0.6 - 3.3	0.66 - 4.25
NOx emission (expected seasonal)	mg/kWh	<39				
Residual fan duty	Pa	100	150	100	160	220
Mass flue rate	kg/h	10 - 48	14 - 69	21 - 104	23 - 138	29 - 187
<b>Water side</b>						
Flow temperature maximum	°C	100 (110)				
Flow temperature operating	°C	20 - 90				
Operating pressure min open vented	bar	0.3				
min pressurised	bar	0.8				
max	bar	3.0	3.5		4.0	
Water contents	ltr	3.1	5.5	6.5	7.5	7.5
Water resistance at 11°C Δt	mbar	460	300	430	460	826
Water resistance at 20°C Δt	mbar	140	90	130	140	250
<b>Electrical</b>						
Main supply	V/Hz	230 / 1 / 50				
Electric rating	W	46	30 - 85	30 - 90	30 - 160	40 - 240
Insulation class	IP	20	20	20	20	20

The products of combustion in the form of hot flue gases are forced through the heat exchanger, transferring their heat to the system water (the flue gas temperature is reduced to approximately 5°C above the temperature of the system return water) then discharged via the condensate collector, vertically through the 80/125 mm (Quinta 30/45) or 100/150 mm (Quinta 65/85/115) combined flue/air connection to atmosphere. Because of the low flue gas exit temperature there will be a vapour cloud formed at the flue gas terminal – this is not smoke, simply water vapour formed during the combustion process. If the controls allow the flow and therefore return temperature to fall below dew point (55°C) this water vapour will begin to condense out in the boiler transferring it's latent heat into the system water, increasing the output of the boiler without increasing gas consumption. Condensation formed within the boiler and flue system is discharged from the boiler to an external drain via the drain pan/siphon supplied.



# Typical installation

Showing Quinta 45/65/85/115  
 (Quinta 30 flow and return connection are reversed)

## Single boiler

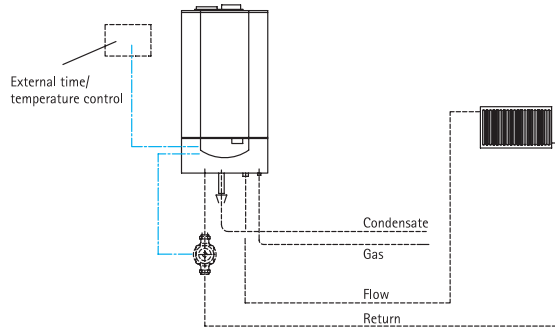

## Single boiler with low loss header

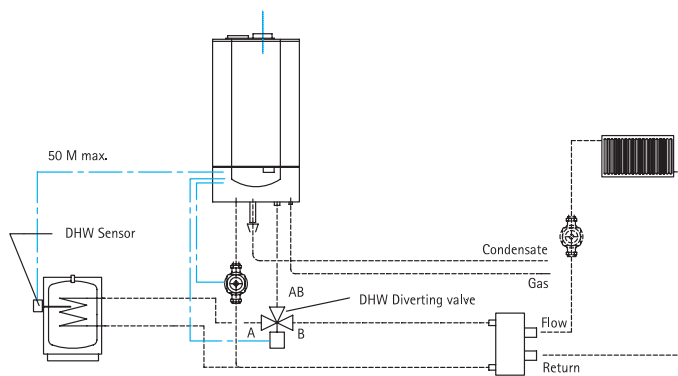

With DHW-Broag priority - Quinta 45/65

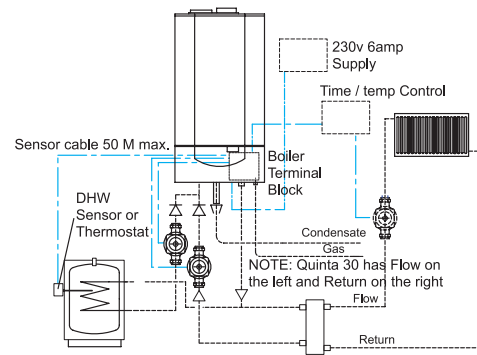

For Quinta 85/115 use a DHW primary pump

## Multiboiler

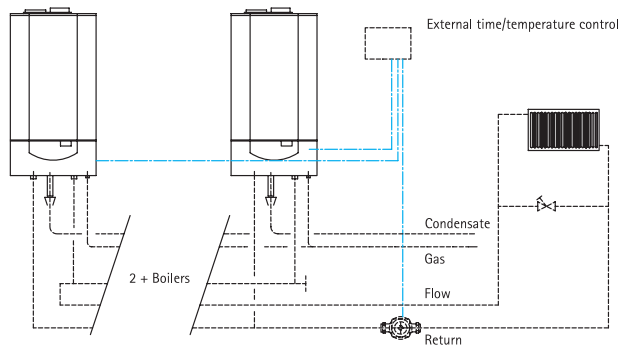

Multiboiler with low loss header (open tube site fabricated)

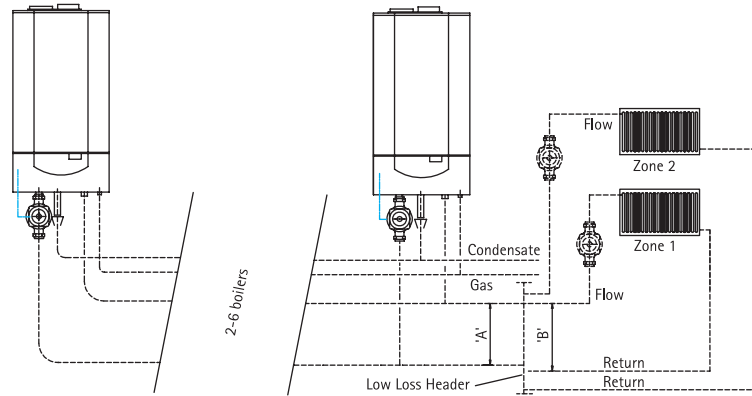

	Quinta 30/45					Quinta 65/85					Quinta 115				
No. of Boilers	2	3	4	5	6	2	3	4	5	6	2	3	4	5	6
Low Loss Header Dia mm	100	125	150	175	200	150	200	200	250	250	150	200	225	250	300
Connecting Pipework mm	50	50	65	80	80	65	80	100	100	125	80	80	100	125	125
Dimension "A" mm	300	375	450	450	600	450	600	600	750	750	450	600	675	750	750
Dimension "B" mm	350	425	500	500	650	500	650	650	800	800	500	650	725	800	800

Typical flue systems  
Concentric room-sealed applications

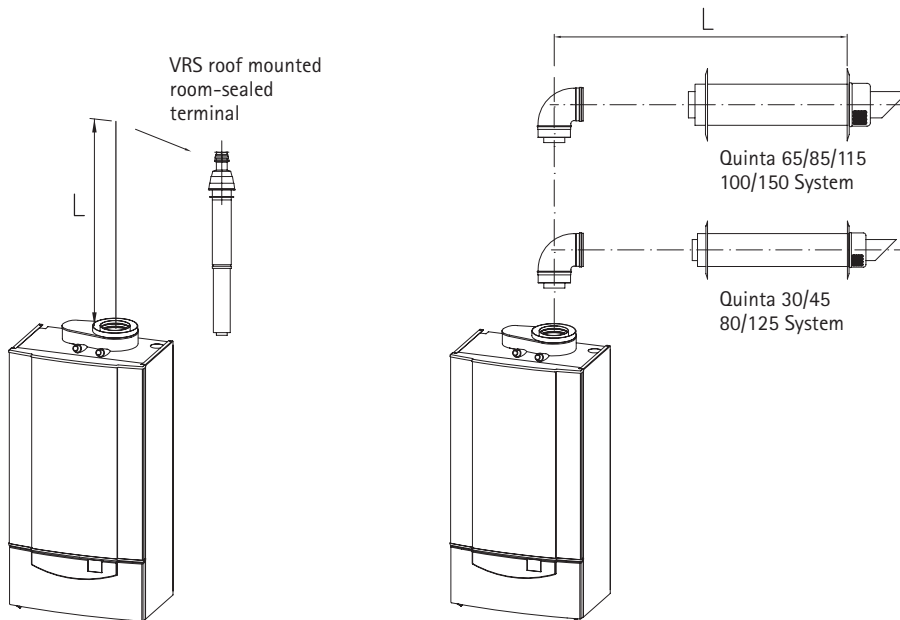

Calculation data – room-sealed applications

		Quinta 30 80/125mm	Quinta 45 80/125mm	Quinta 65 100/150mm	Quinta 85 100/150mm	Quinta 115 100/150mm
max eq. length	m	22	16	13	13	7
eq. length bend 45°	m	1	1	1	1	2
eq. length bend 90°	m	2	2	2	2	3



## Conventional flue

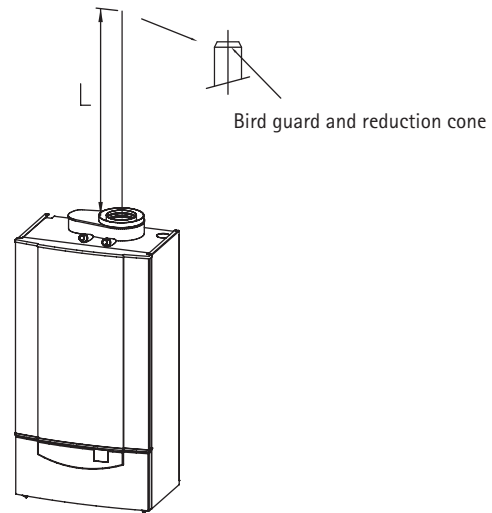

### Calculation data – conventional flue

		Quinta 30 80mm	Quinta 45 80mm	Quinta 65 100mm	Quinta 85 100mm	Quinta 115 100mm
max eq. length	m	40	33	27	24	19
eq. length bend 45°	m	1.2	1.2	1.4	1.4	1.4
eq. length bend 90°	m	4	4	4.9	4.9	4.9

## CLV system (twin pipe – two zone)

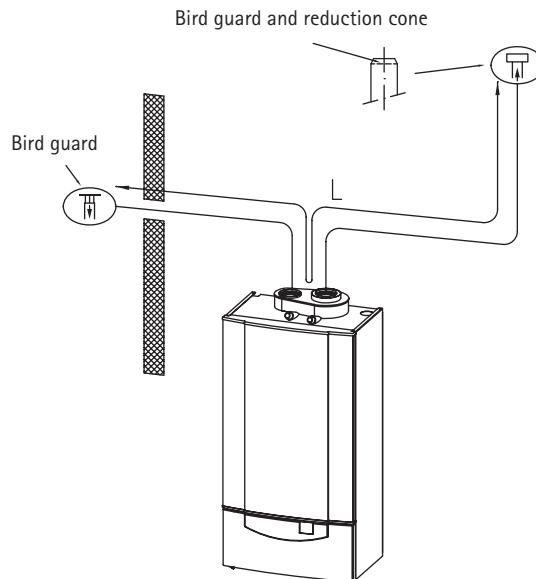

### Calculation data – different pressure zones

		Quinta 30 80mm	Quinta 45 80mm	Quinta 65 100mm	Quinta 85 100mm	Quinta 115 125mm
max eq. length	m	20	20	8	4	58
eq. length bend 45°	m	1.2	1.2	1.4	1.4	1
eq. length bend 90°	m	4	4	4.9	4.9	1.7

For further options see flue booklet.

- Please note that the maximum flue length is calculated on the flue diameter stated.  
Flue lengths will be increased using larger diameter flue pipe.
- Please contact our technical department for assistance if required.

## Electrical installation and controls

### General

The Remeha Quinta Range is supplied as standard with electronic control and flame ionisation safety controls, with a specially designed microprocessor at the heart of the control system.

### Specifications

#### Electrical supply

The Remeha Quinta Range must have a permanent 230V-50Hz single phase supply rated at 6.3 amps. The control unit is not phase /neutral sensitive.

#### Control box

Manufacture:	Gasmodul
Model:	MCBA 1461 D
Supply voltage:	230 V/50 Hz
Electrical rating:	10 VA
Pre-purge time:	0.3 seconds
Post-purge time:	10 seconds
Safety time:	3 seconds
Anti-hunting time:	150 seconds
Pump run on (HTG):	1 -15 minutes
Pump run on (DHW):	5 minutes

#### Fuse specification

The boiler is protected by fuses:

- on the main power supply located in the euro connector socket rated at 6.3 amps (slow acting).
- control circuit 230 volt, 2 amps (fast acting).
- control circuit 24 volt d.c., 4 amps (slow acting).

#### Boiler temperature control

The Remeha Quinta Range has electronic temperature control with flow and return temperature sensors.

The flow temperature can be adjusted between 20 and 90°C.

#### High limit temperature protection

The high limit, temperature protection device switches off and locks out the boiler when the flow temperature exceeds the high limit set point (adjustable). When the fault is corrected the boiler can be restarted by using the reset key on the control panel.

#### Low water protection (flow and content)

The Remeha Quinta Range are supplied with a low water protection on the basis of temperature measurement. By modulating back at the moment that the water flow threatens to fall too low, the boiler is kept operating for as long as possible. In the event of low flow ( $F/R \Delta t > 45^\circ\text{C}$ ) the boiler will shut off and not lockout. If the boiler is fired dry it will go to lockout (code 18).

### External connections

All external connections (except rematic® 2945 C3) are made on the 24 way terminal strip, located in the instrument box at the bottom of the boiler.

$T_{mod}$	Modulating control
$T_{-}$	Enable pair (stage 1)
$T_{\square}$	Outdoor sensor or stage 2
$T_{\ominus}$	DHW sensor/thermostat
$\square/\Delta$	DHW valve 24 V
$*)$	Safety interlock (volt free)
$\square/\Delta/\ominus$	DHW pump/DHW valve 230 V
$\ominus/\square$	System pump (230 V/1 amp.)
$\odot$	Alarm signal (volt free)
$\otimes$	Boiler run signal (volt free)

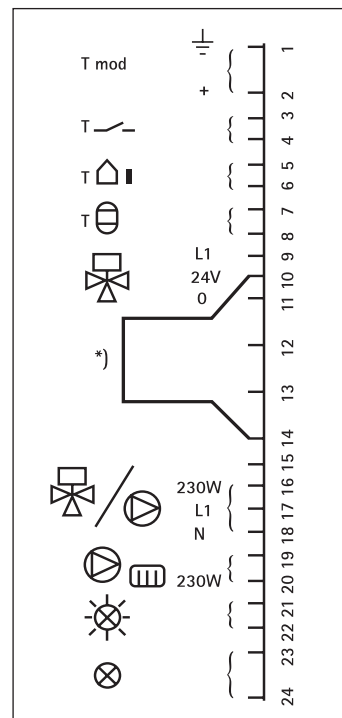



## Boiler control

The Remeha Quinta Range can be controlled using one of the following methods

### Modulating (two wire control)

When using the optional Broag-Remeha compensating controllers the heat output modulates between the minimum and maximum value on the basis of the boiler flow temperature sensor. This applies to both single and multiple boiler installations, under the dictates of a room and/or outside temperature sensor.

Celcia 20 - Optimising room/outside weather compensating control for single boiler. Control is supplied as standard for room compensation. For outside weather compensation the optional o/s sensor must be installed and connected. Control communicating with the boiler directly via two wire interface.

Celcia MC4 - In conjunction with Celcia 20 can provide step control for multi boiler installation of up to four boilers.

Analog control (0-10 volt d.c.)

The heat output modulates between the minimum and the maximum values on the basis of the voltage supplied by an external analog (0-10V) input.

- Temperature based (20 to 90°C). To set the ratio between voltage and the desired flow temperature, see the graph below.

- Output based - fixed parameters (18 to 100%), see the graph below.

0 volt = boiler off

0.5 - 1.8 volt = heat input 18%

1.8 volt - 10 volt = boiler modulates between 18 and 100% on demand.

On/off control (1 x no volt switched pair)

The heat output modulates between the minimum and the maximum value based on the set flow temperature.

High/low control (2 x no volt switched pairs)

The heat output is controlled between part load (18% adjustable) and full load, by means of a two-stage controller.

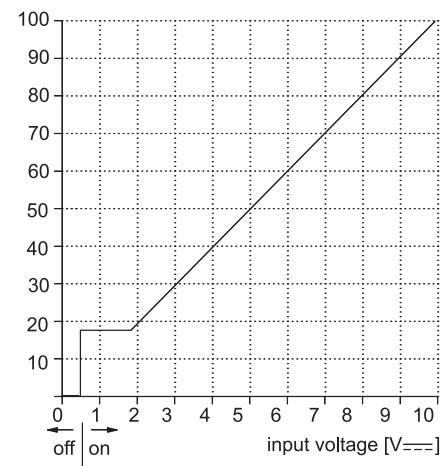
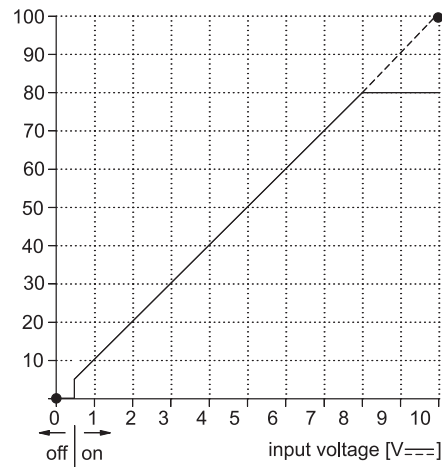

## Priority DHW control

### Temperature control

With a Remeha temperature sensor or with a standard (volt free) DHW thermostat.

Note: will only provide a setting and read out facility with the sensor option.

Primary flow control

- With a three-way diverting valve. (Not Q85/115)
- With a DHW pump.
- Untimed (available 24 hours a day).

## System pump

A system pump can be connected to the boiler (230-1-50 max. 1 amp). If the system pump requires more than 1 amp, terminals can only be used to switch a pump relay.

## System water

Before operation the system should be flushed and filled with mains cold water. As the heat exchanger is aluminium, if water treatment is considered a max. pH level of 8.5 MUST NOT BE EXCEEDED. Broag recommended treatments are - Sentinal 'X-100'® or Fernox 'Copal'®.

## Frost protection

Install the boiler in a frost-free room. The built-in frost protection system is activated as follows: Below 7°C - system pump is switched on if connected to boiler. Below 3°C - boiler is switched on, when the flow temp reaches 10°C the boiler and pump switch off.

NOTE: This control is designed to protect the boiler - for full system protection use a frost thermostat or a weather compensator.

## Remote alarm and boiler run indication

As standard the boiler is supplied with 2 x volt free indicators - Common alarm signal (opens on alarm) and boiler run signal (closes on Boiler run). Maximum 230 volts, 1 amp capacity each.

## Safety interlock

As standard the boiler is supplied with an interlock carrying a 24 volt boiler control circuit.



# TreadLightly

ON THE PLANET

QUINTA RANGE  
CONDENSING



The data published in this technical sales leaflet is based on the latest information (at date of publication) and may be subject to revisions. It should be read in conjunction with our full technical brochure (available on request). We reserve the right to continuous development in both design and manufacture, therefore any changes to the technology employed may not be retrospective, nor may we be obliged to adjust earlier supplies accordingly.

Issue 5 date: 01/02/08



## Broag Ltd. Head Office

Remeha House  
Molly Millars Lane  
Wokingham  
Berkshire RG41 2QP  
T: 0118 978 3434  
F: 0118 978 6977  
E: [boilers@broag-remeha.com](mailto:boilers@broag-remeha.com)

[www.uk.remeha.com](http://www.uk.remeha.com)



Broag UK is committed to carbon offsetting