

A1 Bridge Flue Systems

The FDU

The all new compact flue dilution unit





The all new FDU Compact Flue Dilution Unit

Where space is minimal and height is a problem this all new self contained Flue Dilution System answers all the questions.

Suitable for single or multiple boiler installations up to a maximum of 400kW output.

This system has been specifically designed to handle the exhaust gas products from all types of gas fired boilers including fully condensing types.

This unique system can be pre set to meet varying load demands applicable to the relevant plant output, whilst at all times complying with the discharge requirements of 1% CO₂, as laid down in the Clean Air Act Memorandum and IGE UP/10.

Manufactured as standard from high grade stainless steel the system is designed to be totally watertight. the integral inverter allows for fully programmable step sequencing available for varying boiler loads. This makes it one of the most energy efficient flue dilution units available, creating a 60% improvement in energy efficiency. Under the requirements of the Climate Control Levy some of the outlay for such energy efficient systems is recoverable.

This unit is extremely compact, extending less than one metre into the plant room (assuming a minimum external wall thickness of 150mm). The external 750mm x 750mm combined discharge louvre and air intake extends only 250mm from the outside face of the wall. Where required, this external part of the unit can be powder paint coated to any required RAL colour at a small extra cost.

As with all A1 Bridge Flue Systems products, the FDU is manufactured to the standards required by our ISO 9001 Quality System and it has been designed in full accordance with the requirements of BS6644 and IGE UP/10.

Please note:

Plume effect is a natural occurrence when incorporating fully condensing and high efficiency boilers into flue dilution systems.

Any flue system incorporating fan powered extract should take into consideration the potential for noise effects on the surrounding area.

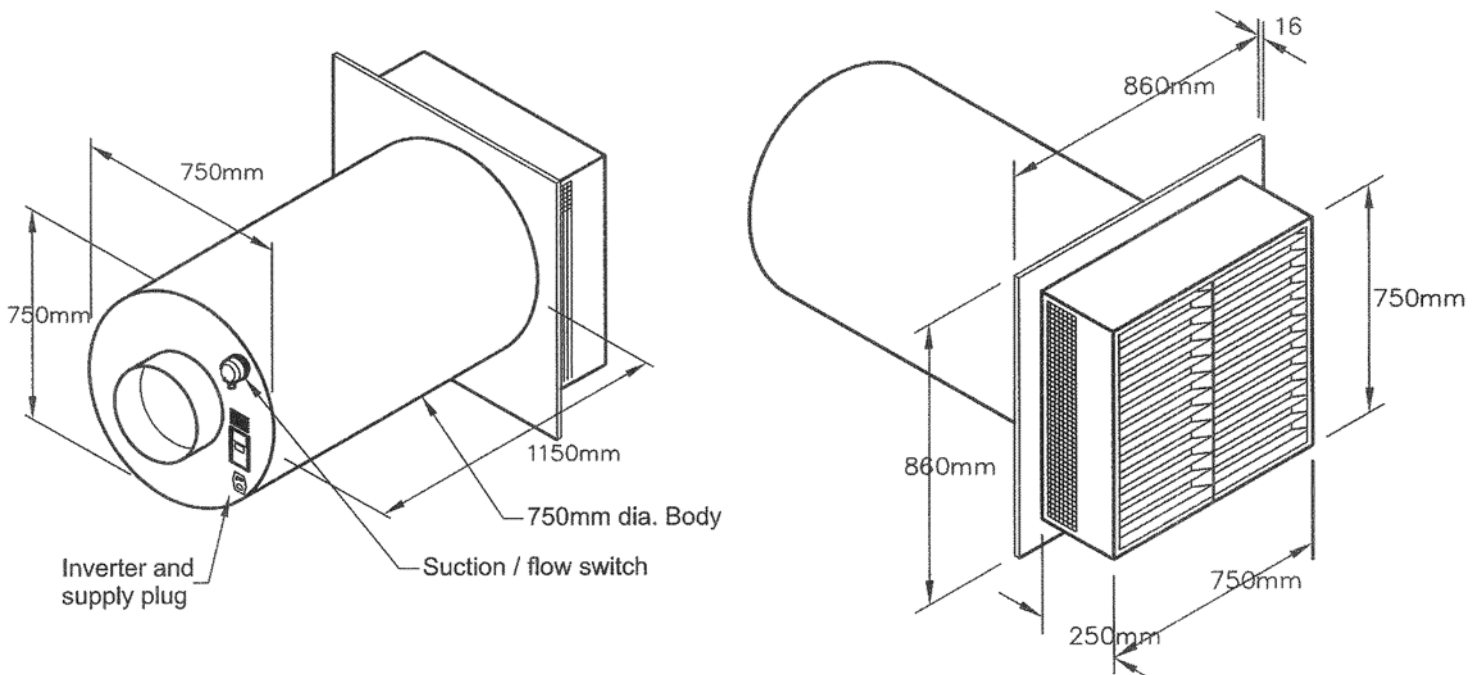



A1 Bridge Flue Systems are long established manufacturers of flue systems supplied throughout the U.K. A1 Flue Systems may be tailor made to suit your exact requirements.

Installations are designed in house by our own design team, operating the latest computer technology.

All flue components are manufactured in our own factory using computer controlled pattern cutting and hand assembly. This allows for efficient production of standard components & specials to be produced often without extended delivery dates.

Quality assurance to ISO9002

Cert. No. 1273/97



Certificate No. 1273/97

